

# CHAPTER 2. ADJUSTMENTS

## [1] Adjustments

### General

Since the following adjustments and settings are provided for this model, make adjustments and/or setup as necessary.

### 1. Adjustments

#### Adjustments of output voltage (FACTORY ONLY)

1. Install the power supply unit in the machine.
2. Set the recording paper and document.
3. When the document is loaded, power is supplied to the output lines. Confirm that outputs are within the limits below.

#### Output voltage settings

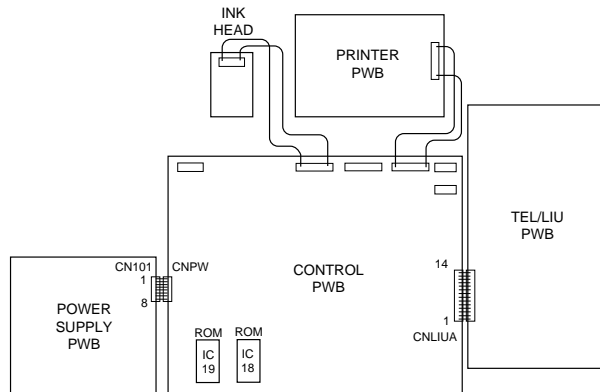

Output	Voltage limits
+5V	4.75V ~ 5.25V
V-REG	5.5V ~ 7.0V
+24V	23.52V ~ 24.48V

Connector No.	CNPW
1	MG
2	MG
3	+24V
4	+24V
5	DG
6	+5V
7	DG
8	VREG

### 2. IC protectors replacement

ICPs (IC Protectors) are installed to protect the motor driver circuit. ICPs protect various ICs and electronic circuits from an overcurrent condition.

The location of ICPs are shown below.

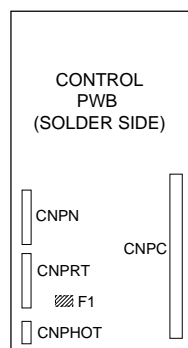

(1) F1 (ICP-S07) is installed in order to protect IC's from an over-current generated in the motor drive circuit. If F1 is open, replace it with a new one.

### 3. Settings

#### (1) Dial mode selector

DIAL mode (Soft Switch No. SW2 DATA No. 1)

(step 1) Select "OPTION SETTING".

KEY: **FUNCTION** (4)

DISPLAY: **OPTION SETTING** ↔ **PRESS ✕ OR #**

(step 2) Select "DIAL MODE".

KEY: **# # # # # # # #**

DISPLAY: **DIAL MODE** ↔ **1=TONE, 2=PULSE**

Cursor  
When initially registering, the mode shows 1=TONE. When registering again, the mode which was registered formerly is shown.

(step 3) Select, using "1" or "2".

KEY: **1**

DISPLAY: **TONE SELECTED**

KEY: **2**

DISPLAY: **PULSE SELECTED**

(step 4) End, using the "STOP" key.

KEY: **STOP**

## [2] Diagnostics and service soft switch

### 1. Operating procedure

#### (1) Entering the diagnostic mode

Press **FUNC** → **9** → **⊗** → **8** → **#** → **7**, and the following display will appear.

ROM Ver. FBS0\*: FBS1\* After 2 sec: **DIAG MODE**

FBS0\*: FBS1\*

Then press the **START** key and country name selected by country select will appear. Select the desired item with the **⊗** key or the **#** key or select with the rapid key. Enter the mode with the **START** key.

(Diag•specifications)

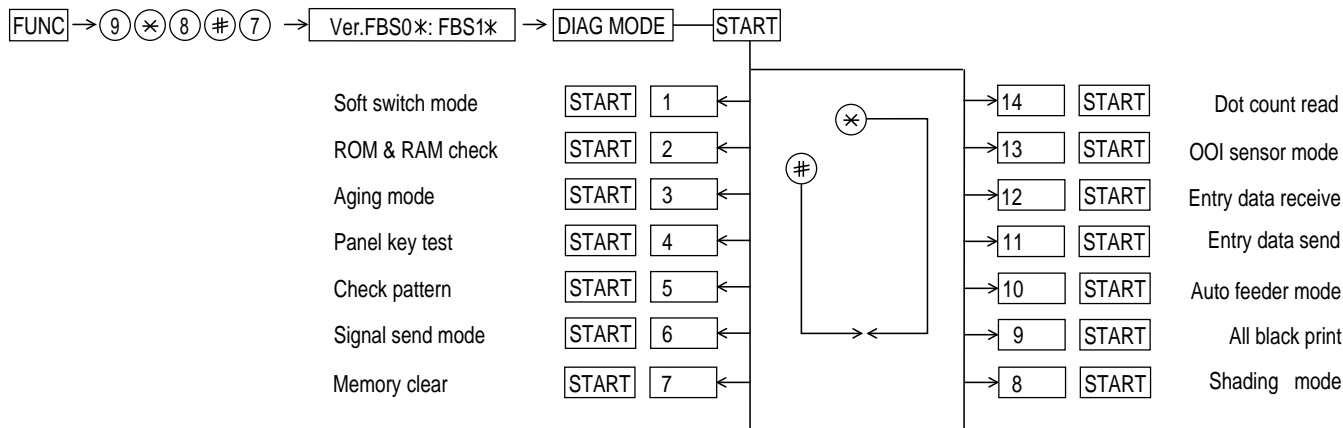

If the dial mode cannot be set, repeat the dial mode operation, performing the following operation.

#### Memory clear when power is turned on

Pressing the **START** and **STOP** keys, turn on the main power, and the following message will be displayed.

**MEMORY CLEAR ?**

Press the **START** key when "MEMORY CLEAR?" appears.

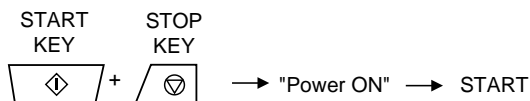

### 2. Diagnostic items

ITEM No.	DIRECT key	Contents	Function
1	1	SOFT SWITCH MODE	Soft switches are displayed and changed. List can be output.
2	2	ROM & RAM CHECK	ROM is sum-checked, and RAM is matched. Result list is output.
3	3	AGING MODE	10 sheets of check patterns are output every 5 minutes per sheet.
4	4	PANEL KEY TEST	Panel keys are tested.
5	5	CHECK PATTERN	Check pattern is output.
6	6	SIGNAL SEND MODE	Various signals of FAX communication are output.
7	7	MEMORY CLEAR	Back-up memory is cleared, and is set at delivery.
8	8	SHADING MODE	Store the shading waveform according to the specified shading document.
9	9	ALL BLACK PRINT	To check the print head, whole dots are printed over the interval of 2 m.
10	10	AUTO FEEDER MODE	Insertion and discharge of document are tested.
11	11	ENTRY DATA SEND	Resisterd content is sent.
12	12	ENTRY DATA RECEIVE	Resisterd content is received and its list is output.
13	13	OOI SENSOR MODE	Check whether the ink sensor can detect nonexistence of ink correctly.
14	14	DOT COUNT READ	Check the ink consumption count value.

### 3. Diagnostic items description

#### 3. 1. Soft switch mode

In this mode, the soft switch are set and the soft switch list is printed.

Soft switch mode screen.

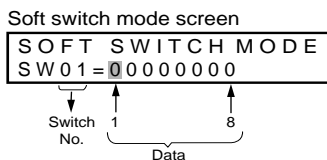

① Switch number selection

- Press START key for setting of the next soft switch. If the soft switch number is the final, pressing START key will exit the soft switch mode.
- Enter two digits of a soft switch number to set the switch number. If a switch number of unexisting soft switch is entered, key error buzzer sounds to reject the input.



② Data number selection

The cursor position shows the data to be set. Pressing # key moves the cursor to the right. If, however, the cursor is on data number 8, pressing # key shifts the cursor to data number 1 of the next switch number. If the switch number is the final, pressing # key will exit the soft switch mode. Pressing ✕ key moves the cursor to the left. If, however, the cursor is on data number 1, pressing ✕ key shifts the cursor to data number 1 of the former switch number. If the switch number is 1, pressing ✕ key will not move the cursor.

③ Data setting method

Press the FUNCTION key, and the data at the position of the cursor will be reversed to 0 when it is 1, or to 1 when it is 0.

④ Outputting method of soft switch list

In the soft switch mode, press the REPORT key, and the soft switch list will be output. If the recording paper runs out or is clogged, the key error buzzer will sound with the process not received.

⑤ Storage of data

- In the following case, the data of the soft switches set will be stored.
- It is shifted to set the next soft switch by pressing the START switch.
  - It is shifted to set the next soft switch with the # key
  - It is shifted to set the last soft switch with the ✕ key
  - It is shifted to set another soft switch by inputting two digits as the switch number. (When 2 digits are completely input.)
  - Output of the soft switch list is started.

#### 3. 2. ROM & RAM check

ROM executes the sum check, and RAM executes the matching test. The result will be notified with the number of short sounds of the buzzer as well as by printing the ROM & RAM check list.

If error does not occur, the buzzer does not sound.

(As for the print format refer to the list function specification.)

No.	Check device	Number of short sounds of buzzer
1	MAIN ROM1	1
2	MAIN ROM2	2
3	CPU ROM/RAM	3
4	S-RAM	4
5	D-RAM	5

The once buzzer sounding pattern is 0.25 sec. ON / 0.25 sec.OFF.

#### 3. 3. Aging mode

If any document is first present, copying will be executed sheet by sheet. If no document is present, the check pattern will be printed sheet by sheet. This operation will be executed at a rate of one sheet per 5minutes, and will be ended at a total of 10 sheets.

#### 3. 4. Panel key test

The mode is used to check whether each key properly operates or not. Since the key is displayed on LCD when the key on the operation panel is pressed, press all the keys. Here, finally press STOP key. When STOP key is pressed, the keys not judged as "pressed" are output in the result list. Here, three LED ports can be turned on alternately during the time from the start of the panel check mode to the end with the stop key.

#### 3. 5. Check pattern

The mode is used to check the state of the printing head. It is ended with the following pattern printed on one printing sheet.

- ① All white
- ② Checkered pattern
- ③ Nozzle test
- ④ All white
- ⑤ Frame line

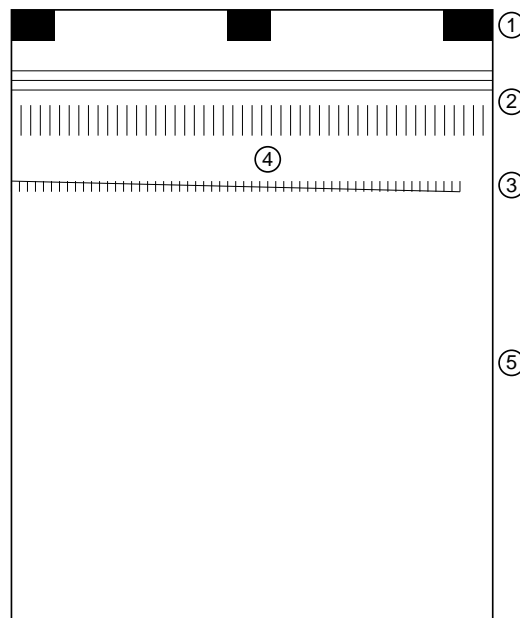

#### 3. 6. Signal send mode

The mode is used to send various signals to the circuit during FAX communication. Every push of START key sends a signal in the following sequence. Moreover, the signal sound is also output to the speaker when the line monitor of the soft switch is on.

- [1] No signal (CML signal turned on)
- [2] 14400BPS (V.33)
- [3] 12000BPS (V.33)
- [4] 14400BPS (V.17)
- [5] 12000BPS (V.17)
- [6] 9600BPS (V.17)
- [7] 7200BPS (V.17)
- [8] 9600BPS (V.29)
- [9] 7200BPS (V.29)
- [10] 4800BPS (V27 ter)
- [11] 2400BPS (V27 ter)
- [12] 300BPS (FLAG)
- [13] 2100Hz (CED)
- [14] 1100Hz (CNG)

### **3. 7. Memory clear**

This mode is used to clear the backup memory and reset to the default settings.

### **3. 8. Shading mode**

This mode is used to store the shading waveform according to the specified shading document.

### **3. 9. All black print**

This mode is used to check the state of the printing head and intentionally overheat it. Press STOP key for the end.

### **3. 10. Auto feeder mode**

This mode is used to check the auto feed function by inserting and discharging the document. In this mode, the feed of the document will be automatically tested if the document is set. Moreover, the number of fed documents will be counted and be displayed on LCD.

### **3. 11. Entry data send**

This mode is used to send the registered data to the remote machine and make the remote machine copy the registered information. When this mode is used for sending, the remote machine must be set to the entry data receive mode.

This information to be sent is as follows.

1. TELEPHONE NUMBER LIST
2. PASSCOD LIST
3. OPTION LIST
4. ANTI JUNK LIST
5. GROUP LIST
6. PRINT SET UP LIST
7. SOFT SW LIST

### **3. 12. Entry data receive**

This mode is used to receive the registered data which is sent from the remote machine and to register the received data in the machine. When this mode is used to receive the information, the remote machine must be set to the entry data send mode

The information to be sent is as follows.

1. TELEPHONE NUMBER LIST
2. PASSCOD LIST
3. OPTION LIST
4. ANTI JUNK LIST
5. GROUP LIST
6. PRINT SET UP LIST
7. SOFT SW LIST

### **3. 13. OOI sensor mode**

This mode is used to check whether the ink sensor can detect nonexistence of ink correctly.

### **3. 14. DOT COUNT READ**

The black, cyan, magenta and yellow ink consumption counter value is indicated.

#### 4. How to make soft switch setting

To enter the soft switch mode, make the following key entries in sequence.

Press **FUNCTION** **9** **\*** **8** **#** **7** **START** **START**



DATA No.	1	2	3	4	5	6	7	8
SFT SW - 1 =	0	0	0	0	0	0	0	0
SFT SW - 1 =	1	0	0	0	0	0	0	0
SFT SW - 1 =	1	0	0	0	0	0	0	0
SFT SW - 1 =	1	0	0	0	0	0	0	0
SFT SW - 1 =	1	0	0	0	0	0	0	0
SFT SW - 1 =	0	0	0	0	0	0	0	0
SFT SW - 35 =	0	0	0	0	0	0	0	0

Press **FUNCTION** key.

Press **#** key.

Press **\*** key.

Bit1 - 8 are set.

Press **START** key during setting.

Soft SW-1- SW-35 are set.

- To finish the settings halfway between SW-1 and SW-35, press the STOP key. In this case, the setting being done to the SW No. on display will be nullified while settings done to the preceding SW Nos. remain in effect.
- When the COPY key is pressed, the contents of soft switches are printed.

The soft switch mode is terminated.

## 5. Soft switch description

### • Soft switch

SW NO.	DATA NO.	ITEM	Switch setting and function				Initial setting	Remarks	
			1		0				
SW I 1	1	Recall interval	Binary input 8 4 2 1 No. = 1 2 3 4 0 1 0 1 (5x60sec=5min)				0	OPTION (1~15)	
	2						1		
	3						0		
	4						1		
	5	Recall times	Binary input 8 4 2 1 No. = 5 6 7 8 0 0 1 0 (Twice)				0	OPTION (0~10)	
	6						0		
	7						1		
	8						0		
SW I 2	1	Dial mode	Pulse	Tone			0	OPTION	
	2	Reception mode	Auto	Manual			1	Recep key	
	3	ECM mode	No	Yes			0	OPTION	
	4	CNG detection in Standby mode	No	Yes			0	OPTION	
	5	Polling Security	On	Off			0	FUNC+3	
	6	Automatic Cover Sheet	No	Yes			1	OPTION	
	7	Junk fax function in manual reception	Yes	No			0		
	8	Anti Junk fax function	Yes	No			0	OPTION	
SW I 3	1	Number of rings for auto receive	Binary input 8 4 2 1 No. = 1 2 3 4 0 1 0 0 (4 times)				0	OPTION (1~5)	
	2						1		
	3						0		
	4						0		
	5	Automatic switching manual to auto receive mode (0:OFF)	Binary input 8 4 2 1 No. = 5 6 7 8 0 0 0 0 (Off)				0		
	6						0		
	7						0		
	8						0		
SW I 4	1	Communication results printout (Transaction report)	Error	Err/Tmr/Mem	Send only	No print	Always	OPTION	
	2		No.1	0	0	0	1		1
	3		No.2	0	0	1	0		1
	3		No.3	1	0	0	0		0
	4	Delay timer before line connect in auto dial	3sec		0sec			0	
	5	Delay timer of after line connect in auto dial	3.6sec		3.0sec	1.7sec	3.0sec	0	
	6		No.5	1	1	0	0		
	7	Number of CNG detect (STAND-BY mode)	1pulse		2pulses	3pulses	4pulses	0	
8	No.7		0	0	1	1			
8	No.8	0	1	0	1	1			
SW I 5	1	Time format	24-hours		12-hours			0	
	2	Date format	Month-Day-Year		Day-Month-Year			1	
	3	Sender's information transmit	Off		On			0	
	4	Footer Print	On		Off			0	
	5	Reserved	—		—			0	
	6	Substitute reception	Off		On			0	
	7	Substitute reception conditions	Reception disable without TSI		Reception enable without TSI			0	
	8	CSI transmission	Off		On			0	

SW NO.	DATA NO.	ITEM	Switch setting and function				Initial setting	Remarks			
			1		0						
SW I 6	1	H2 mode	No		Yes		0				
	2	MH fixed	Yes		No (depend on remote machine)		0				
	3	Reserved	—		—		0				
	4	Reserved	—		—		0				
	5	Modem speed (DCS data reception speed)					V.33 14400 12000				
			No.5					0			0
			No.6					1			1
			No.7					0			1
	8						V.27ter 4800 2400				
			No.5					0			0
			No.6					0			0
			No.7					1			0
	5		V.17		V.29		V.27ter				
			14400 12000	9600 7200	9600 7200	4800 2400	1				
			No.5	1 1 1 1	0 0	0 0		0 0			
			No.6	0 0 0 0	0 0	0 0		0 0			
No.7	0 1 0 1	0 1	1 0	0 0							
8		V.17		V.29		V.27ter					
		14400 12000	9600 7200	9600 7200	4800 2400	0					
		No.7	0 1 0 1	0 1	1 0		0 0				
		No.8	0 0 1 1	1 1	0 0		0 0				
SW I 7	1	Reception speed fixed	NO		V.17- 14400PS		V.29- 9600BPS	V.27ter- 4800BPS	0	When 14400BPS modem used, setting to 14400bps is ignored.	
			No.1	0	1	0	1				
	2		No.2	0	1	1	0	0			
	3	DIS receive acknowledgement during G3 transmission	Twice		0		0				
	4	Non modulated carrier for V29 transmission	On		Off		0				
	5	EOL detect timer	25 sec		13sec		0				
	6	Reserved	—		—		0				
	7	Reserved	—		—		0				
8	Length limitation of copy/send/receive	No limit		Copy/Send:1m Receive:1.5m				0			
SW I 8	1	Digital line equalization setting (Reception)	0Km		1.8Km	3.6Km	7.2Km	0			
			No.1	0	0	1	1				
	2		No.2	0	1	0	1	1			
	3	Dial pausing(sec/pause)	2sec		4sec		1				
	4	Signal transmission level	Binary input 16 8 4 2 1				0				
	5		No. = 4 5 6 7 8				1				
	6		0 1 0 0 0 (-8dBm)				0				
	7						0				
SW I 9	1	CED tone signal interval	1000ms		750ms	500ms	75ms	0			
			No.1	1	1	0	0				
	2		No.2	1	0	1	0	0			
	3	Equalizer freeze control(MODEM)	On		Off		0				
	4	Equalizer freeze conditions	All		7200bps		0				
	5	CED detection time	500ms		1000ms		0				
	6	Reserved	—		—		0				
	7	Reserved	—		—		0				
8	Busy tone detection (after auto dial)	Yes		No		0		U : 0 / C : 1			
SW I 10	1	Reserved	—		—		0				
	2	Reserved	—		—		0				
	3	CI off detection timer (Distinctive ring setting off only)	1200ms		1000ms	700ms	350ms	0			
			No.3	0	1	0	1				
	4		No.4	0	0	1	1	1			
	5	Distinctive ringing setting Factory setting : OFF	OFF		STANDARD	RING1	RING2	RING3	0	OPTION	
			No.5	0	0	1	0	1			
			No.6	0	0	0	1	1			
No.7			0	0	0	0	0				
8		No.8	0	1	0	0	0				

SW NO.	DATA NO.	ITEM	Switch setting and function					Initial setting	Remarks
			1		0				
SW I 11	1	END Buzzer		3sec	1sec	No BEEP	No BEEP	0	
	2		No.1	0	0	1	1	0	
			No.2	0	1	0	1	0	
	3	Communication error treatment in RTN sending mode (reception)	No communication error		Communication error			0	
	4	CNG transmission	No		Yes			0	
	5	Error criterion	10~20%		5~10%			0	
	6	Pulse to Tone change by ✕ key	On		Off			0	
	7	CNG transmission in manual trasmission.	No		Yes			0	
8	Reserved	—		—			0		
SW I 12	1	DTMF signal transmission level (Low)	Binary input 16 8 4 2 1					0	
	2		No. = 1 2 3 4 5					1	
	3		0 1 0 1 0 (-5dBm)					0	
	4							1	
	5							0	
	6	not used	—		—			0	
	7	not used	—		—			0	
	8	not used	—		—			0	
SW I 13	1	DTMF signal transmission level (High)	Binary input 16 8 4 2 1					0	
	2		No. = 1 2 3 4 5					0	
	3		0 0 1 1 1 (-3.5dBm)					1	
	4							1	
	5							1	
	6	not used	—		—			0	
	7	not used	—		—			0	
	8	not used	—		—			0	
SW I 14	1	Reserved	—		—			0	
	2	Reserved	—		—			0	
	3	Reserved	—		—			0	
	4	Reserved	—		—			1	
	5	Reserved	—		—			1	
	6	Reserved	—		—			0	
	7	Reserved	—		—			0	
	8	Reserved	—		—			0	
SW I 15	1	Reserved	—		—			0	
	2	Reserved	—		—			0	
	3	Reserved	—		—			0	
	4	Reserved	—		—			0	
	5	Reserved	—		—			0	
	6	Reserved	—		—			0	
	7	Reserved	—		—			0	
	8	Reserved	—		—			0	
SW I 16	1	Reserved	—		—			1	
	2	Reserved	—		—			0	
	3	Reserved	—		—			0	
	4	Reserved	—		—			0	
	5	Reserved	—		—			1	
	6	Reserved	—		—			0	
	7	Reserved	—		—			0	
	8	Reserved	—		—			0	



SW NO.	DATA NO.	ITEM	Switch setting and function				Initial setting	Remarks	
			1		0				
SW   17	1	Speaker volume (3stages)		HIGH	HIGH	MIDDLE	LOW	1	
			NO.1	0	0	1	1		
	2	Hand-set receiver volume (2stages)		HIGH	HIGH	LOW	LOW	1	
			NO.3	0	0	1	1		
	3	Ringer volume (4stages)		Off	HIGH	MIDDLE	LOW	1	
			NO.5	0	0	1	1		
	4	Reserved	—					0	
			NO.6	0	1	0	1		
SW   18	1	PC I/F mode	Yes		No		1		
	2	Auto reception in PC I/F mode	FAX		PC		1	FUNC+#	
	3	Summer time setting	No		Yes		1	FUNC+3	
	4	Sender's phone number setting	Cannot change		Change allowed		0		
	5	Polling key	Yes		No		0	OPTION	
	6	Activity report print	Automatic printout		No printout when memory full		0	OPTION	
	7	Total communication hours and pages print	Off		On		0		
	8	Line density selector	Fine		Standard		0	OPTION	
SW   19	1	Density adjustment (when Fine/STD mode)		Normal	Faint	Deep	Deep(when Dark Mode)	0	
			No.1	0	0	1	1		
	2	Density adjustment (when Half-tone mode)		Normal	Faint	Deep	Deep(when Dark Mode)	0	
			No.3	0	0	1	1		
	3	HTF correction in Half-tone mode	On		Off		1		
			No.4	0	1	0	1		
	4	MTF correction in Half-tone mode	Strong		Weak		0		
			No.5	0	1	0	1		
5	Separation of image area in the half-tone	On		Off		1			
		No.6	0	1	0	1			
6	Removal of notch in the binary mode	On		Off		1			
		No.7	0	1	0	1			
SW   20	1	Paper set size		LETTER	LEGAL	A4	Letter	0	FUNC+6
			No.1	0	0	1	1		
	2	Media type		Plain	Coated	—	—	0	FUNC+6
			No.2	0	1	0	1		
	3	Print quality when fax printing		—	Normal	Fast Draft	Normal	0	FUNC+6
			No.3	0	0	—	—		
	4	Reserved	—					0	
			No.4	0	0	—	—		
5	Reserved	—					0		
		No.5	0	1	—	—			
SW   21	6	Reserved	—					0	
	7	Reserved	—					1	
	8	Reserved	—					0	
	1	Reserved	—					0	
	2	Reserved	—					1	
	3	Half tone Copy Resolution	200DPIX200DPI		203DPIX196DPI		0		
	4	Reserved	—				0		
	5	Reserved	—				0		
SW   22	6	Copy Ratio for B/W copy		AUTO		100%		0	FUNC+6
			No.6	0	0	0	1		
	7	Reserved	—					0	
			No.7	0	0	0	1		
8	Reserved	—					0		
		No.8	0	0	0	1			

SW NO.	DATA NO.	ITEM	Switch setting and function					Initial setting	Remarks	
			1		0					
SW I 23	1	Reserved	—		—			0		
	2	Reserved	—		—			0		
	3	Reserved	—		—			0		
	4	Reserved	—		—			0		
	5	Reserved	—		—			0		
	6	Reserved	—		—			0		
	7	Reserved	—		—			1		
	8	Reserved	—		—			0		
SW I 24	1	Align cartridge (1~30) for color cartridge	Binary input 16 8 4 2 1					0	FUNC+6	
	2		No. = 1 2 3 4 5					1		
	3		0 1 1 1 1 (15)					1		
	4							1		
	5							1		
	6	FAX printing with paper from manual feeder	Yes		No			0		
	7	FAX printing with color cartridge	Yes		No			0		
	8	FAX printing when low ink detected	Yes		No			0		
SW I 25	1	Align cartridge (1~30) for black cartridge	Binary input 16 8 4 2 1					0	FUNC+6	
	2		No. = 1 2 3 4 5					1		
	3		0 1 1 1 1 (15)					1		
	4							1		
	5							1		
	6	Cartridge alarm	Off		On			0		
	7	Low ink detection in black cartridge	Yes		No			1		
	8	Low ink detection in color cartridge	Yes		No			0		
SW I 26	1	Automatic Reduce of receive	Auto		100%			1	FUNC+6	
	2	Cut off mode (COPY mode)	Continue		Cut-off			0	FUNC+6	
	3	Reserved	—		—			0		
	4	IrDA selection		PCprint	ZAURUS print	File Transfer	DG camera	Off	OPTION	
	5		No.4	0	0	0	0	1		0
	6		No.5	0	0	1	1	0		0
	6	No.6	0	1	0	1	0	0		
	7	Reserved	—		—			0		
8	Reserved	—		—			0			
SW I 27	1	DTMF detection time			50ms	80ms	100ms	120ms	0	
	2		No.1	0	0	1	1			
	3	No.2	0	1	0	1	0			
	3	Protection of remote reception (5 × ×) detect	Yes		No			0	OPTION	
	4	Remote reception with GE telephone	Compatible		Not compatible			1		
	5	Remote operation code figures by external tel (0~9)	Binary input 8 4 2 1					0	OPTION	
	6		No. = 5 6 7 8 (Data No.)					1		
	7		Ex 0 1 0 1					0		
8						1				
SW I 28	1	Busy tone detection ON/OFF time (Shorter duration)	350ms		150ms			0		
	2	Busy tone detection ON/OFF time (Longer duration)			650ms	900ms	2700ms	900ms	0	
	3		No.2	0	0	1	1			
	3	No.3	0	1	0	1	1			
	4	Busy tone continuous sound detect time	5sec		10sec			1		
	5	Busy tone detect continuation sound detect	No		Yes			0		
	6	Busy tone detect intermittent sound detect	No		Yes			0		
	7	Busy tone detection pulse number			2pulses	4pulses	6pulses	10pulses	0	
8	No.7		0	0	1	1				
	No.8	0	1	0	1	1				

SW NO.	DATA NO.	ITEM	Switch setting and function				Initial setting	Remarks	
			1		0				
SW   29	1	TAD connect	Yes		No		0	OPTION	
	2	Fax switching when A.M. full	Yes		No		0	OPTION	
	3	Section time of quiet detection		30s	40s	50s	60s	0	
	4		No.3	0	0	1	1		
	5	Number of CNG detect (AM mode )		1pulse	2pulses	3pulses	4pulses	0	
	6		No.5	0	0	1	1		
	6		No.6	0	1	0	1		
	7	Reserved	—		—		0		
8	Reserved	—		—		0			
SW   30	1	Quiet detect time	Binary input 8 4 2 1				0	OPTION	
	2		No. = 1 2 3 4						
	3		0 1 0 0 (4sec)						
	4								
5	Quiet detect start timing	Binary input 8 4 2 1				0			
6		No. = 5 6 7 8							
7		0 1 0 1 (5sec)							
8									
SW   31   34	1	Reserved	—		—		0		
	2	Reserved	—		—		0		
	3	Reserved	—		—		0		
	4	Reserved	—		—		0		
	5	Reserved	—		—		0		
	6	Reserved	—		—		0		
	7	Reserved	—		—		0		
	8	Reserved	—		—		0		
SW   35	1	Reserved	—		—		0		
	2	Reserved	—		—		0		
	3	Reserved	—		—		0		
	4	Reserved	—		—		1		
	5	Reserved	—		—		0		
	6	Reserved	—		—		0		
	7	Reserved	—		—		0		
	8	Reserved	—		—		0		

• **Soft switch function description**

**SW1 No. 1 ~ No. 4 Recall interval**

Choice is made for a recall interval for speed and rapid dial-numbers. Use a binary number to program this. If set to 0 accidentally, 1 will be assumed.

**SW1 No. 5 ~ No. 8 Recall times**

Choice is made as to how many recall attempts should be made. Use a binary number to program this.

**SW2 No. 1 Dial mode**

Switch the type according to the telephone circuit connected to the facsimile.

- 1 : PULSE DIAL
- 0 : TONE DIAL

**SW2 No. 2 Reception mode**

Auto/manual receiving mode is set.

**SW2 No. 3 ECM mode**

Used to determine ECM mode function. Refer to the following table.

SW2- No. 3 ECM MODE		0	0	0	0	0	0	0	0	1	1	1	1	1	1	1
SW6- No. 1 MH FIXED		0	1	0	1	0	1	0	1	0	1	0	1	0	1	0
Compression method	ECM MMR mode	Yes	No	Yes	No	No	No	No	No	No	No	No	No	No	No	No
	ECM MR mode	Yes	No	Yes	No	Yes	No	Yes	No	No	No	No	No	No	No	No
	ECM MMH mode	Yes	Yes	No	No	Yes	Yes	No	No	No	No	No	No	No	No	No
	ECM MH mode	Yes	Yes	Yes	Yes	Yes	Yes	Yes	Yes	No	No	No	No	No	No	No
	MR Mode	Yes	No	Yes	No	Yes	No	Yes	No	Yes	No	Yes	No	Yes	No	Yes
	MH Mode	Yes	Yes	Yes	Yes	Yes	Yes	Yes	Yes	Yes	Yes	Yes	Yes	Yes	Yes	Yes

(Depending on remote machine)

**SW2 No. 4 CNG detection in Standby mode**

When setting to "1", the CNG signal detection function during standby stops.

**SW2 No. 5 Polling Security**

This switch is employed to enable or disable the polling operation using the ID code verification function, in order to prevent unauthorized polling operation.

**SW2 No. 6 Automatic Cover Sheet**

When "0" (=YES) is selected, the cover sheet is automatically sent after transmission of the original to notify the receiver of the number of original sheets transmitted.

**SW2 No. 7 Junk fax function in manual reception**

It is set whether Junk fax is functioned in the manual receiving mode or not.

**SW2 No. 8 Anti Junk fax function**

This function is used to receive data from a specific remote machine (station registered in entry mode). It is the function that refused a reception in the case that TSI of remote machine matched with fax number of the station registered.

- 0 : No
- 1 : Yes

**SW3 No. 1 ~ No. 4 Number of rings for auto receive (0 : No ring receive)**

When the machine is set in the auto receive mode, the number of rings before answering can be selected. It may be set from one to nine rings using a binary number. If the soft switch was set to 1, a direct connection is made to the facsimile. If a facsimile. If it was set to 0 accidentally, receive ring is set to 1.

**SW3 No. 5 ~ No. 8 Automatic switching manual to auto receive mode (0 : OFF)**

Choice is made after how many rings in the manual receive mode it should be automatically change to auto answer mode or remain in the manual receive mode. Entering the binary number 0 forces the machine to remain in the manual answer mode. If a number between 1 and 9 is entered, the machine will go into the answer mode after the given number of rings. However, it can be used as an ordinary telephone if the handset is taken off the hook before this programmed number is finished.

**SW4 No. 1 ~ No. 3 Communication results printout (Transaction report)**

Every communication, the result can be output. As usual, it is set to print the timer sending communication error alone. If No.1 : 0 No.2 : 0 No.3 : 1 are set, printing is always on (printed ever if it is normally ended).

- 000 : Error, timer and memory sending/receiving
- 010 : Sending
- 110 : Continuous printing
- 100 : Not printed
- 001 : Communication error

**SW4 No. 4 Delay timer before line connect in auto dial**

Delay time between the dial key input and line connection under the auto dial mode.

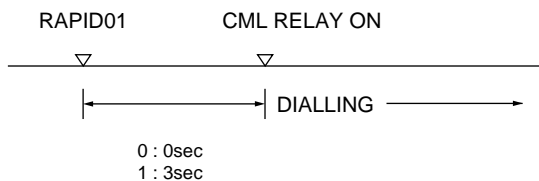

**SW4 No. 5, No. 6 Delay timer of after line connect in auto dial**

Delay time between the line connection and dial data output under the auto dial mode.

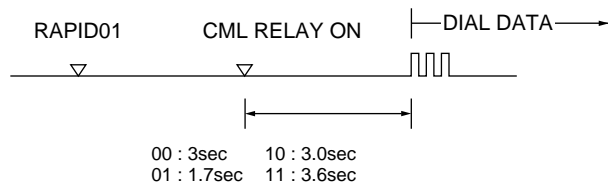

**SW4 No. 7, No. 8 Number of CNG detect (STAND-BY mode)**

Used for detection of CNG in 1 to 4 pulses.

**SW5 No. 1 Date format**

Used to select date display/print formats.

**SW5 No. 2 Time format**

When this switch is set to "0", time is displayed in 12-hour system. When set to "1", 24-hour system.

**SW5 No. 3 Sender's information transmit**

When it is set at 0, sender's name, sending page number and so on are automatically printed in the recording paper on the receiving side during transmission. Thus, the sender can be known on the receiving side.

- 0 : Applied.
- 1 : Not applide.

**SW5 No. 4 Footer print**

When set to "1", the date of reception, the sender machine No., and the page No. are automatically recorded at the end of reception.

**SW5 No. 5 Reserved**

Set to "0".

**SW5 No. 6 Substitute reception**

Selection of substitute reception in the case of recording paper exhausted or paper jam. If set to "NO", auto receive is disabled even when the receive memory is ready to receive.

Substitute reception is not performed even during receive operation.

**SW5 No. 7 Substitute reception conditions**

Selection of substitute reception according to existence of TEL number from transmitting side. Initial setting allows substitute reception without CSI. If set to "no", the receiver cannot receive any documents.

**SW5 No. 8 CSI transmission**

CSI signal contains the sender's phone number registered in the machine. If this switch is set to "1", no sender's name will be printed at the receiving side.

**SW6 No. 1 H2 mode**

Used to determine H2 mode (15 sec transmission mode). When set to OFF, H2 mode is inhibited even though the transmitting machine has H2 mode.

**SW6 No. 2 MH fixed**

Normally set to allow automatic selection of MH and MR mode according to the remote side.

If set to 1, the mode is fixed to MH and is useful if the remote side is a MH only unit ; or a lot of image distortion is met due to a bad line.

**SW6 No. 3, No. 4 Reserved**

Set to "0".

**SW6 No. 5 ~ No. 8 Modem speed (DCS data reception speed)**

Used to determine the initial modem speed. The default is 14400BPS (V17). It may be necessary to program it to a slower speed when frequent line fallback is encountered, in order to save the time required for the fallback procedure.

**SW7 No. 1, No. 2 Reception speed fixed**

The transferable speed of modem in the receiving mode is set.

**SW7 No. 3 DIS receive acknowledgement during G3 transmission**

Used to make a choice of whether reception of NSF (DIS) is acknowledged after receiving two NSF's (DISs) or receiving one NSF (two DISs). It may be usefull for overseas communication to avoid an echo suppression problem, if set to 1.

**SW7 No. 4 Non modulated carrier in V29 transmission**

Though transmission of a non-modulated carrier is not required for transmission by the V29 modem according to the CCITT Recommendation, it may be permitted to send a non-modulated carrier before the image signal to avoid an echo suppression problem.

It may be usefull for overseas communication to avoid an echo suppression problem, if set to 1.

**SW7 No. 5 EOL detect timer**

Used to make a choice of whether to use the 25-second or 13-second timer for detection of End of line.

This is effective to override communication failures with some facsimile models that have longer End of line detection.

**SW7 No. 6, No. 7 Reserved**

Set to "0".

**SW7 No. 8 Length limitation of copy/send/receive**

Used to set the maximum page length.

To avoid possible paper jam, the page length is normally limited to 1 meter for copy or transmit, and 1.5 meters for receive.

It is possible to set it to "No limit" to transmit a long document, such as a computer print form, etc. (In this case, the receiver must also be set to no limit.)

**SW8 No. 1 , No. 2 Digital line equalization setting (Reception)**

Needs to be set to the line characteristics. A guide line is the distance between the exchange office and the telephone terminal. Since it needs not to be set in the normal case since it has been set to 1.8Km, it should be corrected in case communication failures occur frequently.

**SW8 No. 3 Dialing pausing (sec/pause)**

Pauses can be inserted between telephone numbers of direct dial connection. Selection of 4 sec or 2 sec pause is available.

**SW8 No. 4 ~ No. 8 Signal transmission level**

Used to control the signal transmission level in the range of-0dB to -31dB. The factory setting is at -10dB (MODEM output).

**SW9 No. 1, No. 2 CED tone signal interval**

For international communication, the 2100Hz CED tone may act as an echo suppression switch, causing a communication problem.

Though SW9 No. 1 , No.2 are normally set to 0, it should be changed this time between the CED tone signal to eliminate the communication problem caused by echo.

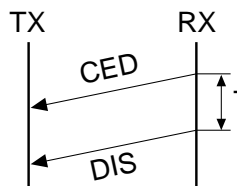

**SW9 No. 3 Equalizer freeze control (MODEM)**

This switch is used to perform reception operation by fixing the equalizer control of modem for the line which is always in unfavorable state and picture cannot be received. Usually, the control is executed according to the state of line where the equalizer setting is changed always.

**SW9 No. 4 Equalizer freeze conditions**

Setting which specifies SW9 No.3 control only in condition of 7200bps modem speed.

**SW9 No. 5 CED detection time**

The detection time of the CED signal from the called side in the auto calling mode is set.

**SW9 No. 6, No. 7 Reserved**

Set to "0".

**SW9 No. 8 Busy tone detection (after auto dial)**

Use to set busy tone detection in auto dialing.

**SW10 No. 1, No. 2 Reserved**

Set to "0".

**SW10 No. 3, No. 4 CI off detection timer (Distinctive ring setting off only)**

Set the minimum time period of CI signal interruption which affords to be judged as a CI OFF section.

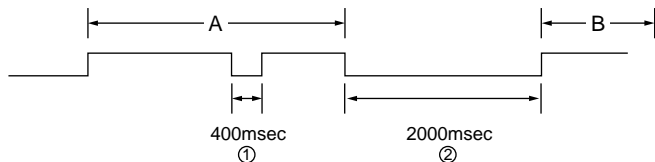

**SW10 No. 5 ~ No. 8 Distinctive ringing setting (Factory setting:OFF)**

When the ringing setting is turned off, all of the CI signal are received. When any of the standard, and ring patterns 1 through 3 is selected for the ringing setting, only the selected CI signal is received.

CI signal patterns

The CI signal patterns consists of the standard pattern, and ring patterns 1 through7. The standard pattern is the conventional one.

STANDARD	
RING PATTERN 1 for USA	
RING PATTERN 2 for USA	
RING PATTERN 3 for USA	
RING PATTERN 1 for CANADA	
RING PATTERN 2 for CANADA	
RING PATTERN 3 for CANADA	

**SW11 No. 1 , No. 2 End buzzer**

The sounding length of the buzzer for normal end of operation is set.

**SW11 No. 3 Communication error treatment in RTN sending mode (reception)**

The operation is set when the RTN signal is received in the G3 transmission mode.

**SW11 No. 4 CNG transmission**

When set to "0", this model allows CNG transmission by pressing the Start key in the key pad dialing mode. When set to "1", CNG transmission in the key pad dialing mode cannot be performed. In either case. CNG transmission can be performed in the auto dial mode.

**SW11 No. 5 Error criterion**

Used to select error criterion for sending back RNT when receiving image data.

**SW11 No. 6 Pulse to Tone change by ✕ key**

When setting to 1, the mode is changed by pressing the ✕ key from the pulse dial mode to the tone dial mode.

**SW11 No. 7 CNG transmission in manual transmission**

In case of CCITT there is no need to send the CNG signal in manual transmission mode .This setting allows this signal to be sent in case of manual transmission so as to inform the other party's machine that the machine is FAX.

**SW11 No. 8 Reserved**

Set to "0".

**SW12 No. 1 ~ No. 5 DTMF signal transmission level (Low)**

The transmission level of DTMF signal is adjusted. (lower frequency)

00000 : 0 dBm

↓

11111 : -15.5 dBm

**SW12 No. 6 ~ No. 8 not used**

Set to "0".

**SW13 No. 1 ~ No. 5 DTMF signal transmission level (High)**

The transmission level of DTMF signal is adjusted. (higher frequency)

00000 : 0 dBm

↓

11111 : -15.5 dBm

**SW13 No. 6 ~ No. 8 not used**

Set to "0".

**SW14 No. 1 ~ No. 3 Reserved**

Set to "0".

**SW14 No. 4 , No. 5 Reserved**

Set to "1".

**SW14 No. 6 ~ No. 8 Reserved**

Set to "0".

**SW15 No. 1 ~ No. 8 Reserved**

Set to "0".

**SW16 No. 1 Reserved**

Set to "1".

**SW16 No. 2 ~ No. 4 Reserved**

Set to "0".

**SW16 No. 5 Reserved**

Set to "1".

**SW16 No. 6 ~ No. 8 Reserved**

Set to "0".

**SW17 No. 1, No. 2 Speaker volume (3stages)**

Speaker volume:  
The sound volume of the speaker in the on-hook mode is set.

**SW17 No. 3, No. 4 Hand-set receiver volume (2stages)**

Handset volume:  
The volume of sound heard from the receiver is set.

**SW17 No. 5, No. 6 Ringer volume (4stages)**

Ringer volume:  
The calling sound volume of CI signal receiving is set.

**SW17 No. 7, No. 8 Reserved**

Set to "0".

**SW18 No. 1 PC I/F mode**

PC I/F mode:  
The interface with the personal computer is selected.

**SW18 No. 2 Auto reception in PC I/F mode**

Automatic receiving of I/F mode:  
Which receives the call is determined.

**SW18 No. 3 Summer time setting**

This is used to set YES/NO of automatic clock adjustment for summer time.

**SW18 No. 4 Sender's phone number setting**

Used to make a choice of whether the registered sender's phone number can be changed or not. If the switch is set to "1", new registration of the sender's phone number is disabled to prevent accidental wrong input.

**SW18 No. 5 Polling key**

If this switch is set to 1, the last of Rapid key works as polling key.

**SW18 No. 6 Activity report print**

This soft switch is used to select : whether or not to print out the activity report when the memory is full. An activity report can be printed when the following key entry command is made.

"FUNCTION", "2", "#", "START"

After producing the activity report, all the data in the memory will be cleared.

When the switch function is set to "0" (no), the data in the memory will be deleted from the oldest as it reaches the maximum memory capacity.

**SW18 No. 7 Total communication hours and pages print**

Used to make a choice of whether the total communication time and pages are recorded in the activity report.

**SW18 No. 8 Line density selection**

Used to set the transmission mode which is automatically selected when the Resolution key is not pressed. In the copy mode, however, the fine mode is automatically selected unless the Resolution key is manually set to another mode.

**SW19 No. 1, No. 2 Density adjustment (when Fine/STD mode)**

This is used for density adjustment in fine/standard mode. Adjust the density according to that of frequently used original.  
Set to "Dark" for darker reading (either in the auto or the dark mode) of light original. Set to "Light" for lighter reading (either in the auto or the dark mode) of dark original.  
Set to "Dark only in dark mode" for darker reading only in the dark mode.

**SW19 No. 3, No. 4 Density adjustment (when Half-tone mode)**

This is used for density adjustment in the half tone.

**SW19 No. 5 HTF correction in Half-tone mode**

In the half tone mode, image area is separated from character area and processed separately to eliminate unclear character transmission. This switch is used to change the criteria of judgement of separation. When "Strong" (=1) is selected, more area is judged as character area, providing clearer characters. On the contrary, however, edges of image area may be emphasized. It is advisable to restrict the use of this function only when clear characters must be transmitted, and to use the function of "Weak" (= 0) for general cases.

**SW19 No. 6 MTF correction in Half-tone mode**

This allows selection of MTF correction (dimness correction) in the half tone mode. When "Strong" (= 1) is selected, the whole image becomes soft and mild, On the contrary, however, clearness of characters will be reduced. Normally set to "Strong" (= 1).

**SW19 No. 7 Separation of image area in the half tone**

This allows selection of MTF correction (dimness correction) in the half tone mode. When "NO" (= 1) is selected, the whole image becomes soft and mild, On the contrary, however, clearness of characters will be reduced. Normally set to "NO" (= 0).

**SW19 No. 8 Removal of notch in the binary mode**

The notch signal is removed in the binary mode.

**SW20 No. 1, No. 2 Paper set size**

Set the size of recording paper for reception and list print.

**SW20 No. 3~ No. 5 Media type**

Set the type of recording paper for reception and list print.

**SW20 No. 6 , No.7 Print quality when fax printing**

Set the printing method for reception and list print.

**SW20 No. 8 Reserved**

Set to "0".

**SW21 No. 1 ~ No. 6 Reserved**

Set to "0".

**SW21 No. 7 Reserved**

Set to "1".

**SW21 No. 8 Reserved**

Set to "0".

**SW22 No. 1 Reserved**

Set to "0".

**SW22 No. 2 Reserved**

Set to "1".

**SW22 No. 3 Half tone copy resolution**

The image resolution conversion rate is set in the copy mode.  
0 : 203 DPI X 196 DPI (1.53 times X 1.47 times )  
1 : 200 DPI X 200 DPI (1.50 times X 1.50 times )

**SW22 No. 4, No. 5 Reserved**

Set to "0".

**SW22 No. 6 ~ No.8 Copy Ratio for B/W copy**

Set the magnification when "PRESET" is selected in copy mode.

**SW23 No. 1 ~ No. 6 Reserved**

Set to "0".

**SW23 No. 7 Reserved**

Set to "1".

**SW23 No. 8 Reserved**

Set to "0".

**SW24 No. 1 ~ No. 5 Align cartridge (1~30) for color cartridge**

After the color cartridge has been mounted press

"FUNCTION", "6", "⌘", "⌘", "⌘", "START"

to print Bidirectional Alignment Pattern.

On the printed test page, locate the number under the Bidirectional Alignment pattern that comes closest to forming a perfectly straight line.

**SW24 No. 6 Fax printing with paper from manual feeder**

To print the received picture in hand paper feed mode, set "1".

**SW24 No. 7 Fax printing with color cartridge**

To print the received picture with the color cartridge set "1".

#### **SW24 No. 8 Fax printing when low ink detected**

To print the received picture in "Low Ink" state, set "1".

#### **SW25 No. 1 ~ No. 5 Align cartridge (1~30) for black cartridge**

After the black cartridge has been mounted press

"FUNCTION", "6", "⌘", "⌘", "⌘", "START"

to print Bidirectional Alignment Pattern.

On the printed test page, locate the number under the Bidirectional Alignment pattern that comes closest to forming a perfectly straight line.

#### **SW25 No. 6 Cartridge alarm**

Set existence/nonexistence of alarm tone alarming the failure of return of cartridge to the home position.

#### **SW25 No. 7 Low ink detection in black cartridge**

Set detection/nondetection of black ink "Low ink".

#### **SW25 No. 8 Low ink detection in color cartridge**

Set detection/nondetection of color ink "Low ink".

#### **SW26 No. 1 Automatic reduce of receive**

If set to 1, it is reduced automatically when receiving.

#### **SW26 No. 2 Cut off mode (COPY mode)**

Whether the excessive part is printed on the next recording paper or discarded is selected to copy a document which is longer than the recording paper.

#### **SW26 No. 3 Reserved**

Set to "0".

#### **SW26 No. 4 ~ No. 6 IrDA selection**

Set the other party of Ir communication.

#### **SW26 No. 7, No. 8 Reserved**

Set to "0".

#### **SW27 No. 1, No. 2 DTMF detection time**

Used to set detect time of DTMF (Dual Tone Multi Frequency) used in remote reception (5 ⌘ ⌘).

The longer the detect time is, the less the error detection is caused by noises.

#### **SW27 No. 3 Protection of remote reception (5 ⌘ ⌘) detect**

Used to set the function of remote reception (5 ⌘ ⌘). When set to "1", the remote reception function is disabled.

#### **SW27 No. 4 Remote reception with GE telephone**

(Corresponding to TEL made by GE) P.B.X.

"1": Compatible with TEL mode by GE

"0": Not compatible

- When sending (5 ⌘ ⌘) for remote reception with a GE manufactured telephone remote reception may not take place because of special specifications in their DTMF.

To overcome this, a soft SW is provided to change the modem setting to allow for remote reception.

- If this soft SW is set to "1", other telephone sets may be adversely affected.

#### **SW27 No. 5 ~ No. 8 Remote operation code figures by external tel (0~9)**

Remote operation codes can be changes from 0 through 9. If set to greater than 9, it defaults to 9. The "5 ⌘ ⌘" is not changed.

Ex-7⌘⌘ (Default : 5 ⌘ ⌘).

#### **SW28 No. 1 Busy tone detection ON/OFF time (Shorter duration)**

The initial value of detection is set according to electric condition.

The set value is changed according to the local switch board. (Erroneous detection of sound is reduced.)

Normally the upper limit is set to 2700msec. and the lower limit to 150msec.

If erroneous detection is caused by sound, etc., adjust the detection range.

The lower limit can be set in the range of 350msec to 150msec.

#### **SW28 No. 2, No. 3 Busy tone detection ON/OFF time (Longer duration)**

Similarly to SW-28 No.1, the set value can be varied.

The upper limit can be set in the range of 650msec to 2700msec.

#### **SW28 No. 4 Busy tone continuous sound detect time**

Set detecting time busy tone for 5 seconds or as is PTT.

#### **SW28 No. 5 Busy tone detect continuation sound detect**

Used to select detection of the continuous sound of certain frequency.

#### **SW28 No. 6 Busy tone detect intermittent sound detect**

Used to select detection of the intermittent sound of certain frequency.

#### **SW28 No. 7, No. 8 Busy tone detection pulse number**

Used to set detection of Busy tone intermittent sounds.

#### **SW29 No. 1 TAD connect**

When connecting the answering machine to the extension telephone jack.

Set to "1".

#### **SW29 No. 2 Fax switching when A.M.full**

If the answering machine's memory (tape) is full and there is no response, the machine automatically switches to Fax reception.

#### **SW29 No. 3, No. 4 Section time of quiet detection**

The switch which sets the time from the start of detection function to the end of the function.

#### **SW29 No. 5, No. 6 Number of CNG detect (AM mode)**

Used for detection of CNG in 1 to 4 pulses.

#### **SW29 No. 7, No. 8 Reserved**

Set to "0".

#### **SW30 No. 1 ~ No. 4 Quiet detect time**

When an answering machine is connected, if a no sound state is detected for a certain period of time, the machine judges it as a transmission from a facsimile machine and automatically switches to the Fax mode.

#### **SW30 No. 5 ~ No. 8 Quiet detect start timing**

Inserts a pause before commencing quiet detection.

#### **SW31 No. 1 ~ No. 8 Reserved**

Set to "0".

#### **SW32 No. 1 ~ No. 8 Reserved**

Set to "0".

#### **SW33 No. 1 ~ No. 8 Reserved**

Set to "0".

#### **SW34 No. 1 ~ No. 8 Reserved**

Set to "0".

#### **SW35 No. 1 ~ No. 3 Reserved**

Set to "0".

#### **SW35 No. 4 Reserved**

Set to "1".

#### **SW35 No. 5 ~ No. 8 Reserved**

Set to "0".



### [3] Troubleshooting

Refer to the following actions to troubleshoot any of problems mentioned in 1-4.

- [1] A communication error occurs.
- [2] Image distortion produced.
- [3] Unable to do overseas communication.
- [4] Communication speed slow due to FALLBACK.
  - Increase the transmission level SOFT SWITCH 8-4, 5, 6, 7, 8. May be used in case [1] [2] [3].
  - Decrease the transmission level SOFT SWITCH 8-4, 5, 6, 7, 8. 5. May be used in case [3].

- Apply line equalization SOFT SWITCH 8-1, 2. May be used in case [1] [2] [3] [4].
- Slow down the transmission speed SOFT SWITCH 6-5, 6, 7, 8. May be used in case [2] [3].
- Replace the TEL/LIU PWB. May be used in all cases.
- Replace the control PWB. May be used in all cases.

\* If transmission problems still exist on the machine, use the following format and check the related matters.

TO: \_\_\_\_\_ ATT: \_\_\_\_\_ Ref.No.: \_\_\_\_\_  
 CC: \_\_\_\_\_ ATT: \_\_\_\_\_ Date: \_\_\_\_\_  
 FM: \_\_\_\_\_ Dept: \_\_\_\_\_  
 \_\_\_\_\_ Sign: \_\_\_\_\_

***** Facsimile communication problem *****			Ref.No.:																				
From: Mr. _____		Fax Tel No.: _____	Date: _____																				
Our customer	Name _____	Tel No. _____																					
	Address _____	Fax No. _____																					
	Contact person _____	Model name _____																					
Other party	Name _____	Tel No. _____																					
	Address _____	Fax No. _____																					
	Contact person _____	Model name _____																					
Problem mode	Line: Domestic / international _____	Model: G3	Phase: A, B, C, D.																				
	Reception / Transmission	Automatic reception / Manual reception																					
		Automatic dialing / Manual dialing / Others																					
Frequency: _____	%	ROM version: _____																					
Confirmation item			Please mark problem with an X. No problem is: 0.																				
			<table border="1" style="width: 100%; text-align: center;"> <tr> <td>A1</td><td>A2</td><td>B1</td><td>B2</td><td>C1</td><td>C2</td><td>D1</td><td>D2</td><td>E1</td><td>E2</td> </tr> <tr> <td> </td><td> </td><td> </td><td> </td><td> </td><td> </td><td> </td><td> </td><td> </td><td> </td> </tr> </table>	A1	A2	B1	B2	C1	C2	D1	D2	E1	E2										
	A1	A2	B1	B2	C1	C2	D1	D2	E1	E2													
		Transmission level setting is (    ) dB at our customer																					
		Transmission level (    ) dBm Reception level (    ) dBm By level meter at B1 and B2																					
Comment																							
Countermeasure																							

\*\*\*\* Please attach the G3 data and activity report on problem. \*\*\*\*

\* Please complete this report before calling the "TAC" hotline if problem still occurs.

## [4] Error code table

### 1. Communication error code table

#### G3 Transmission

Code	Final received signal	Error Condition (Receiver side)
0	Incomplete signal frame	Cannot recognize bit stream after flag
1	NSF, DIS	Cannot recognize DCS signal by echo etc. Cannot recognize NSS signal (FIF code etc)
2	CFR	Disconnects line during reception (carrier missing etc)
3	FTT	Disconnects line by fall back
4	MCF	Disconnects line during reception of multi page Cannot recognize NSS, DCS signal in the case of mode change
5	PIP or PIN	The line is hung up without replying to telephone request from the receiving party.
6	RTN or RTP	Cannot recognize NSS, DCS signal after transmit RTN or RTP signal.
7	No signal or DCN	No response in receiver side or DCN signal received* (transmitter side)
8	–	Owing to error in some page the error could not be corrected although the specified number of error retransmission was attempted.
11	–	Error occurred after or while reception by the remote (receiving) machine was revealed to be impossible.
12	–	Error occurred just after fallback.
13	–	Error occurred after a response to retransmission end command was received.

#### G3 Reception

Code	Final received signal	Error Condition (Receiver side)
0	Incomplete signal frame	Cannot recognize bit stream after flag
1	NSS, DCS	Cannot recognize CFR or FTT signal Disconnects line during transmission (line error)
2	NSC, DTC	Cannot recognize NSS signal (FIF code etc)
3	EOP	Cannot recognize MCF, PIP, PIN, RTN, RTP signal
4	EOM	Cannot recognize MCF, PIP, PIN, RTN, RTP signal in the case of mode change
5	MPS	The line is hung up without replying to communication request.
6	PR1-Q	Cannot recognize PIP, PIN signal in the case of TALK request
7	No signal or DCN	No response in transmitter (cannot recognize DIS signal) or DCN signal received* (receiver side)
8	–	Error occurred upon completion of reception of all pages.
9	–	Error occurred when mode was changed or Transmission/Reception switching was performed.
10	–	Error occurred during partial page or physical page reception.
11	–	Error occurred after or during inquiry from the remote (transmitting) machine as to whether reception is possible or not.
12	–	Error occurred during or just after fallback.
13	–	Error occurred after the retransmission end command was received.